

**SLSI80 MASTER STATION WITH DISPLAY WIRING**

<b>RJ45 &amp; RJ11</b>	<b>Master &amp; Display Function (Max distance 150m)</b>	<b>10PR Twisted Cable Colours</b>
M1	Individual audio line to krone 1 pair 1+	Blue } blue&white pair
M2	Individual audio line to krone 1 Pair 1-	White }
M3	Common dialing line A to krone 0 pair 1+	Orange } orange&white pair
M4	Common dialing line B to krone 0 pair 1-	White }
M5	Common dialing line C to krone 0 pair 2+	Green } green&white pair
M6	Common dialing line D to krone 0 pair 2-	White }
M7	Common engaged line to krone 0 pair 4+	Brown&white pair
M8	Common ground line to krone 0 pair 4-	Slate&white + brown&red pair *
+	Common Display +24V to Power supply	Blue&red
-	Common Display Ground to Power supply	Orange&red + green&red pair *
L1	Common Display RS485 + line to krone 0 pair 5+	Slate } slate&white pair
L2	Common Display RS485 + line to krone 0 pair 5-	White }

\* Only one pair required on short cable runs.

**WARNING: Please Note**

The controller must be installed as close as possible to the master stations. Each master must have it's own 10 pair cable installed back to the controller and wired as the above table. On short cable runs of less than 40 metres M8 and -Display GND can be reduced to only one pair.

Only one master with display on a system can be cabled far away (Max 150m) the other three must be on short cable runs. Only the furthest master must have a 120E termination resistor across the L1 and L2 display terminals. If more than one master is installed, all the Common Lines must be commoned in a connector block at the controller. Then with short single cores pumped into the krone. If more than 2 masters are installed on a controller, a separate MPS-2405 power supply must be used to power the 2 extra display sockets. The MPS-2405 GND must be common to the controller GND and the +24v must only connect to the additional display +sockets.

MASTER RJ45 WIRING DIAGRAM

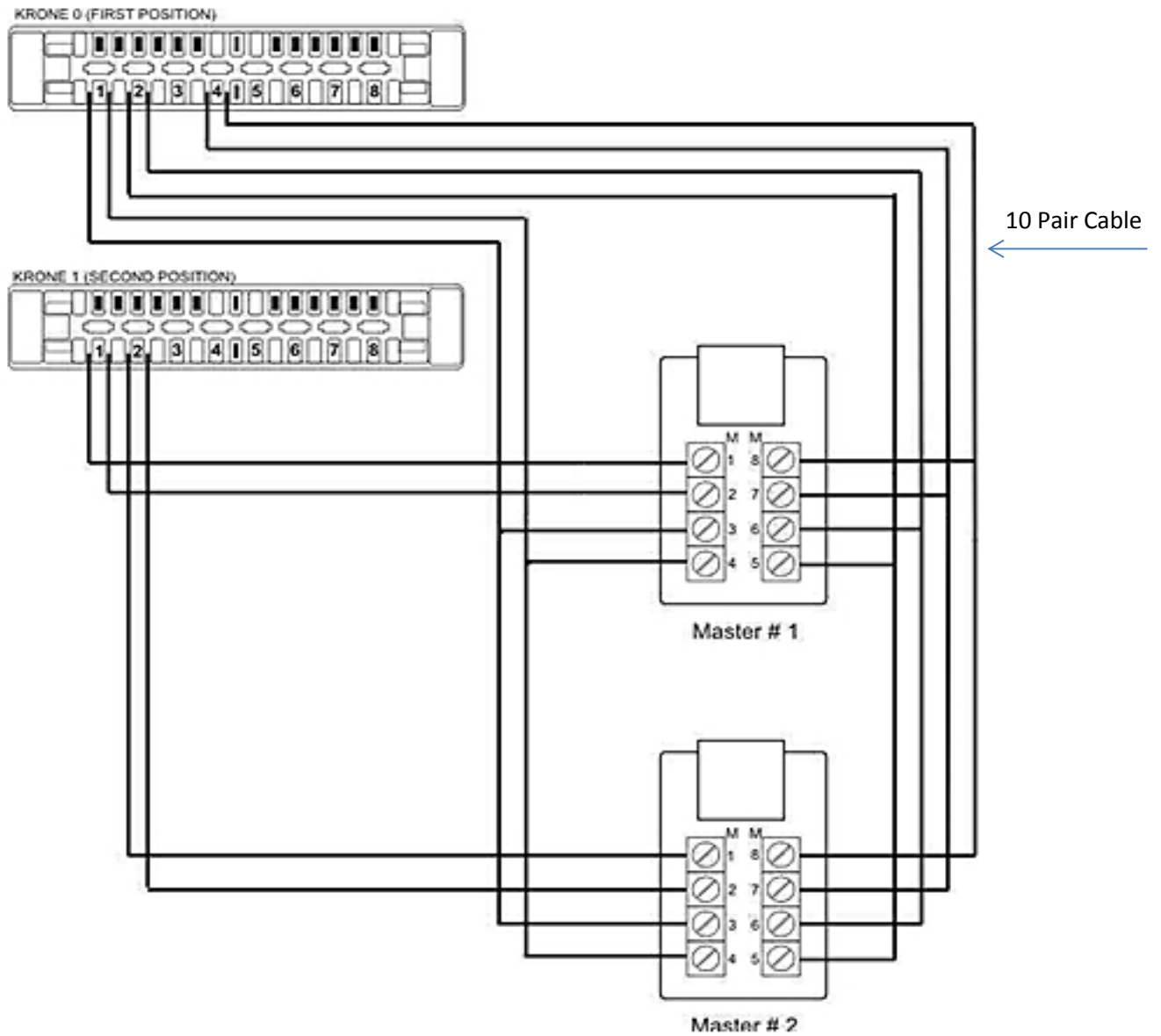

# DISPLAY RJ11 WIRING DIAGRAM

